

HORN TWEETER LOUDSPEAKER GDWT 9/80/5F

9 5155 033

TECHNICAL DATA

Rated impedance	4	8	Ω
Voice coil resistance	2,9	6,3	Ω
Rated frequency range	4 to 20		kHz
Resonance frequency	-		kHz
Recommended crossover frequency	4,5		kHz
Power handling capacity, P1/P2 measured with filter	80/6		W
Max. power	200/15		W
Sensitivity	100		dB
Flux density	1,16	1,29	T
Energy in air gap	106	119,5	mJ
Air - gap	25/3/0,815	25/3/0,745	mm
Voice coil height		1,8	mm
Magnet			
- material		ferrite	
- dimensions		70/32/15	mm
- mass		0,23	kg
Mass of loudspeaker		0,8	kg

The loudspeaker has flexible wire leads and an air gap with ferrofluid.

AVAILABLE VERSIONS

- GDWT 9/80/5F - 4 Ω , catalogue number 9 5155 033 01
- GDWT 9/80/5F - 8 Ω , catalogue number 9 5155 033 02

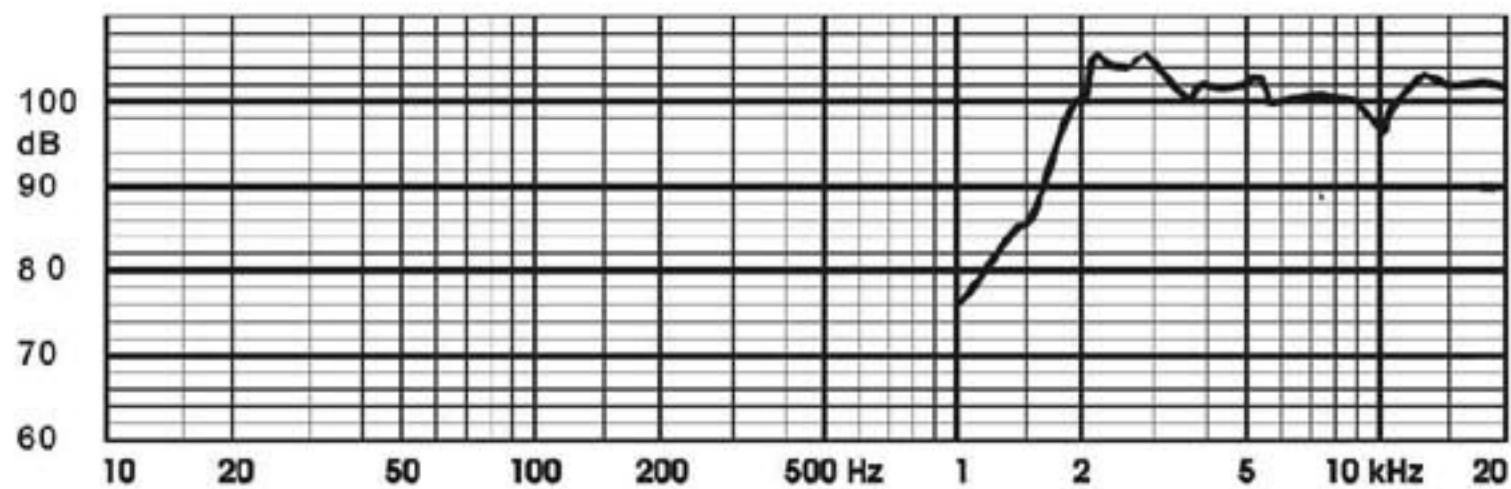
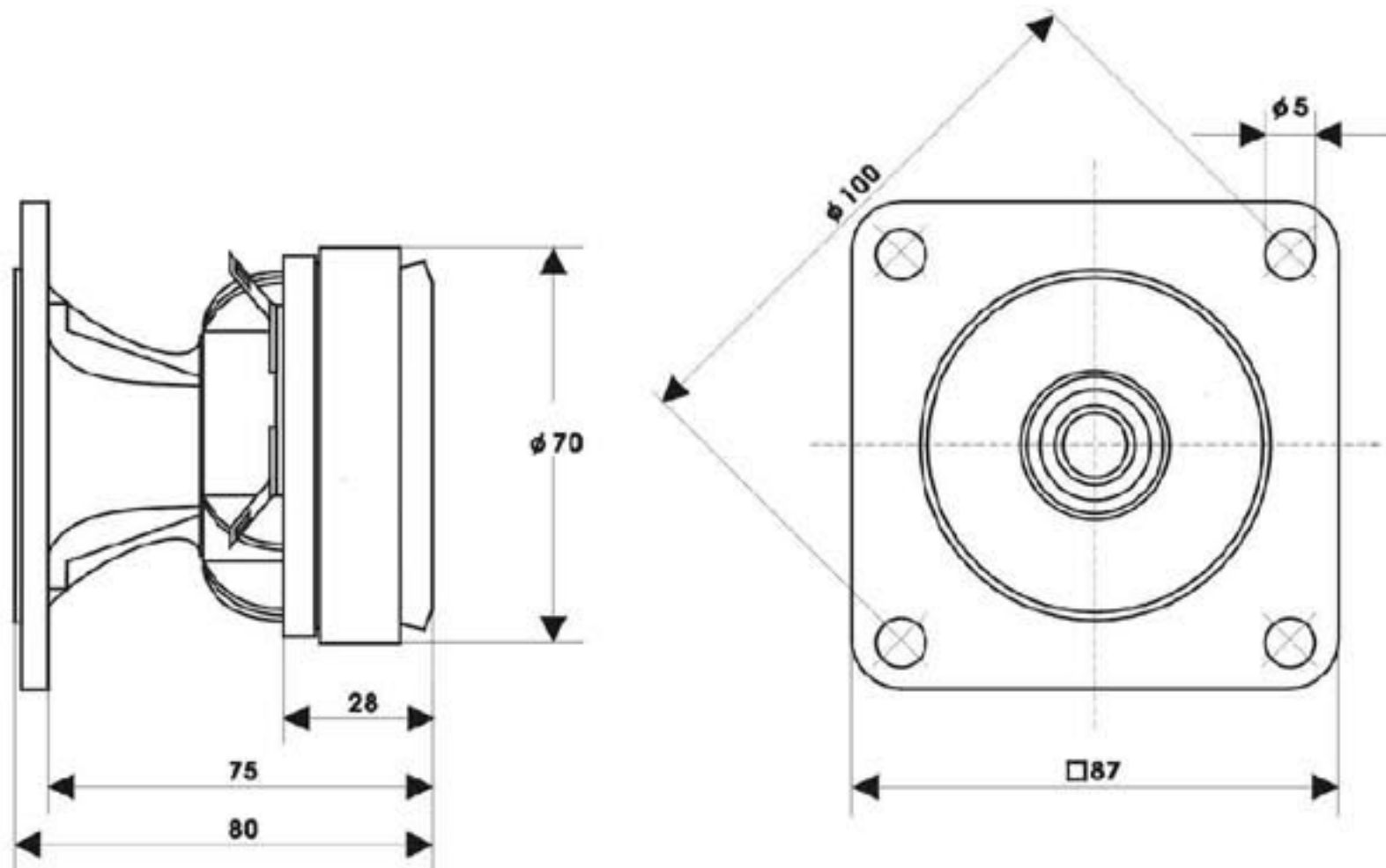

FREQUENCY RESPONSE CURVE
Measured in anechoic room at 1W/1m, free field.

TONSIL

ul. Czarniejewska 11, 62-300 Września
phone/fax: (061) 436 05 70, www.tonsilproducent.pl

1